



Photo 1

Photo 2

Photo 1: Dual Lamp DL 026 Series with on/off switch
Photo 2: Dual Lamp DL 026 Series with movement sensor

Versatile – base lamp or hand lamp

Long-life energy saving lamp

On/off switch or movement sensor

Connections for further lamps

The Dual Lamp 026 is available with on/off switch or movement sensor (the movement sensor version was designed to eliminate the need for a door switch). The PIR movement sensor switches the lamp on when the enclosure door is opened. The switch-on time is reset with every further registered movement. The movement sensor does not react to movement on the other side of glass and so can be used in enclosures with glass doors.



Technical Data

Luminosity	1000 Lm (equals 100W light bulb)
Lamp type	energy saving lamp, E27 socket
Service life	10,000h
Mounting	screw fixing (e.g. 35mm DIN rail)
Casing	plastic according to UL94 V-0, light grey
Weight	approx. 0.6kg
Fitting position	variable
Operating / Storage temperature	-20 to +50°C (-4 to +122°F) / -45 to +70°C (-49 to +158°F)
Operating / Storage humidity	max. 90 % RH (non-condensing)
Protection type / Protection class	IP20 / II (double insulated)
Approvals	-
Accessories	see illustration below
Note	120VAC and DC voltages on request

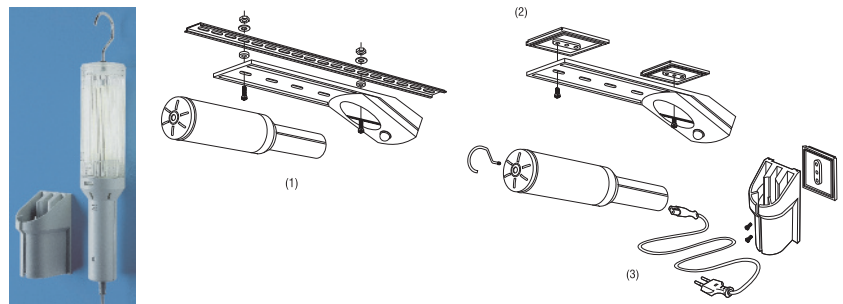
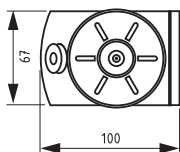
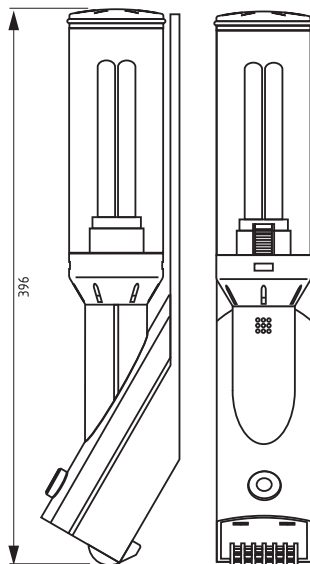

(1) Standard screw fixing to DIN rail

(2) 2 self-adhesive fixing plates, Art. No. 09515.0-00

(3) Wall holder with connection cable (2m), hook and self-adhesive fixing plate, Art. No. 03410.0-00.

By using an additional wall holder the lamp can be used as a hand lamp.

Art. No.	Operating voltage	Power consumption	Switch	Connection
02600.0-00	230VAC, 50Hz	20 W	on/off push switch	6-pole screw connector 2.5mm ² (torque 0.5Nm max.) for power connection, further lamps and external door contact switch
02601.0-00	230VAC, 50Hz	20 W	PIR movement sensor, approx. 3min. fixed switch-on duration	4-pole screw connector 2.5mm ² (torque 0.5Nm max.) for power connection and further lamps